

## Electronic Engineering

### Sheet # 1: Diodes

- 1- Determine the forward voltage and forward current for the diode in the Figure (a) for each of the diode models. Also find the voltage across the limiting resistor in each case. Assume  $r_d' = 10 \text{ ohm}$  at the determined value of forward current.
- 2- Determine the reverse voltage and reverse current for the diode in the Figure (b) for each of the diode models. Also find the voltage across the limiting resistor in each case. Assume  $I_R = 1 \mu\text{A}$ .

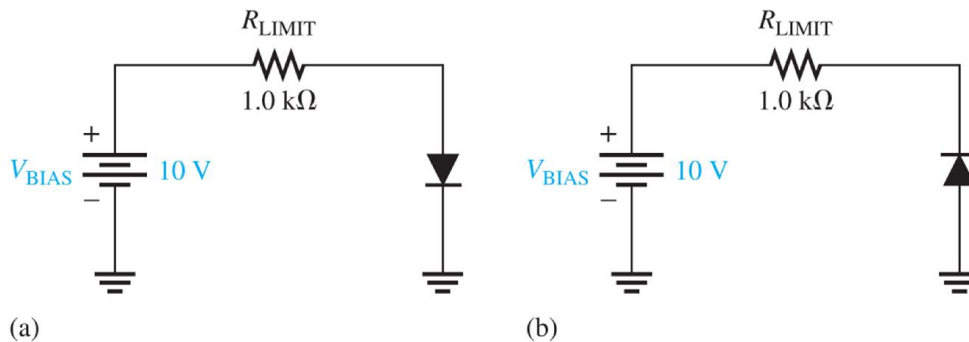

- 3- Calculate the current through  $48 \Omega$  resistor in the circuit shown in the Figure. Assume the diodes to be of silicon and forward resistance of each diode is  $1 \Omega$ .

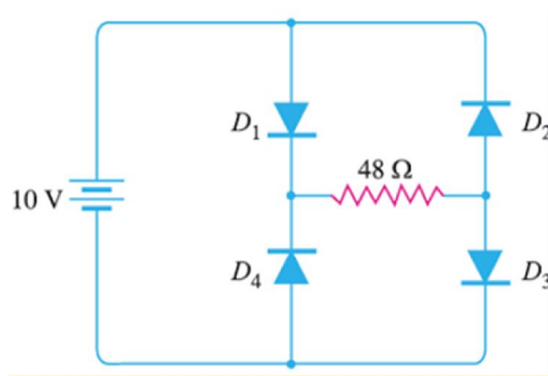

- 4- Determine the current  $I$  in the circuit shown in the Figure. Assume the diodes to be of silicon and forward resistance of diodes to be zero.

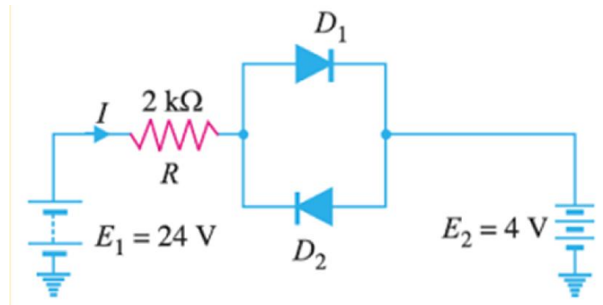

5- Find  $V_Q$  and  $I_D$  in the network shown. Use practical model.

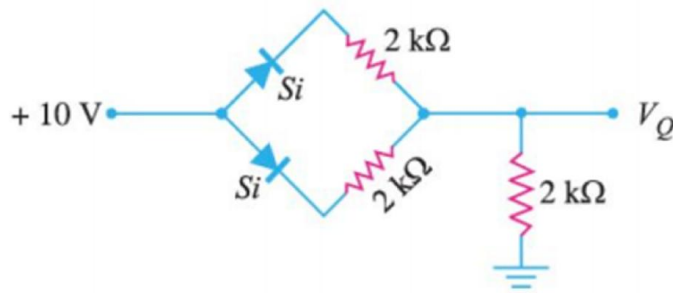

6- Determine current through each diode in the circuit shown. Use practical model. Assume diodes to be similar .

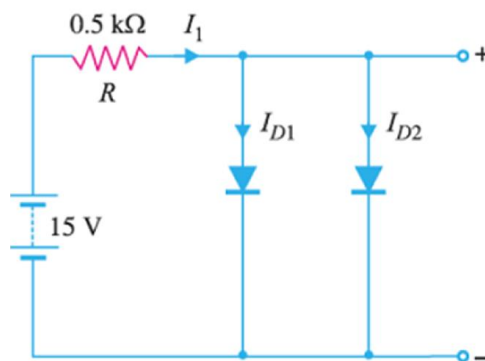

7- Determine the currents  $I_1$ ,  $I_2$ ,  $I_3$  for the network shown. Use practical model for the diodes.

